

2A, 18V, 340K High-Efficiency Synchronous-Rectified Buck Converter

General Description

The uP1715 is a high-efficiency synchronous-rectified buck converter with internal power switch. With internal low $R_{DS(ON)}$ switches, the high-efficiency buck converter is capable of delivering 2A output current over a wide input voltage range from 4.5V to 18V. The output voltage is adjustable from 0.925V to 16V by a voltage divider. Other features for the buck converter include adjust soft-start, chip enable, over-voltage, under-voltage, over-temperature and over-current protections. It is available in a space saving SOP-8L and PMSOP-8L packages.

Ordering Information

Order Number	Package Type	Top Marking
uP1715PSA8	SOP-8L	uP1715P
uP1715PRU8	PMSOP-8L	uP1715P

Note:

- (1) Please check the sample/production availability with uPI representatives.
- (2) uPI products are compatible with the current IPC/JEDEC J-STD-020 requirement. They are halogen-free, RoHS compliant and 100% matte tin (Sn) plating that are suitable for use in SnPb or Pb-free soldering processes.

Pin Configuration

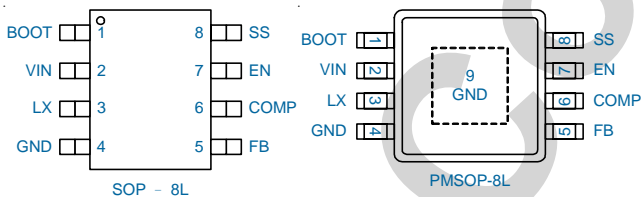

Features

- 4.5V to 18V Input Voltage Range
- Adjustable Output from 0.925V to 16V
- 2A Output Current
- Accurate Reference: 0.925V ($\pm 1.5\%$)
- Up to 93% Conversion Efficiency
- Integrated Low $R_{DS(ON)}$ Upper and Lower MOSFET Switches: 130m Ω
- Current Mode PWM Operation
- Constant 340kHz Fixed-Frequency Operation
- Programmable Soft-Start
- Integrated Boot Diode
- Over Voltage and Under Voltage Protection
- Over Temperature and Over Current Protection
- SOP-8L and PMSOP-8L Packages
- RoHS Compliant and Halogen Free

Applications

- Battery-Powered Portable Devices
 - MP3 Players
 - Digital Still Cameras
 - Wireless and DSL Modems
 - Personal Information Appliances
- 802.11 WLAN Power Supplies
- FPGA/ASIC Power Supplies
- Laptop, Palmtops, Notebook Computers
- Portable Information Appliances

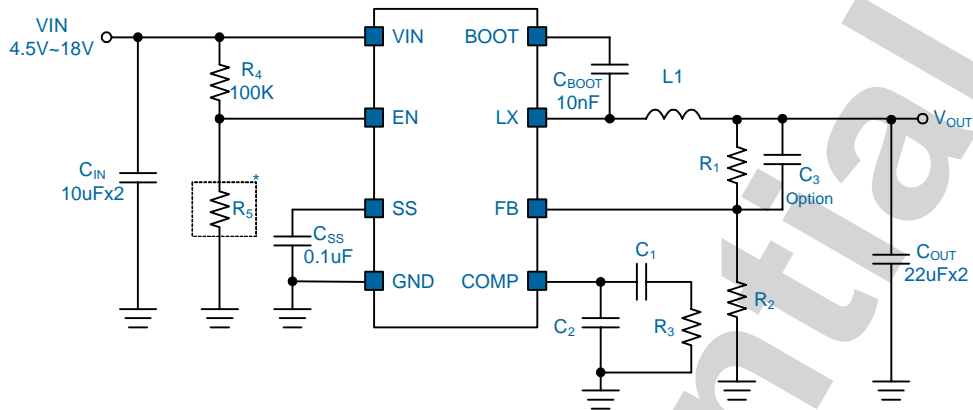
Typical Application Circuit

Note: * check BOM List for EN Pin Application table below.

V_{IN}	V_{OUT}	L1	C_{OUT}	R1	R2	R3	C1	C2
12V	1V	3.3uH	22uF*2	1.5K	18K	6.2K	6.8nF	N/A
12V	1.2V	3.3uH	22uF*2	3K	10K	7.5K	6.8nF	N/A
12V	2.5V	6.8uH	22uF*2	16.9K	10K	15K	2.2nF	68pF
12V	3.3V	10uH	22uF*2	26.1K	10K	6.8K	3.9nF	N/A
12V	5V	10uH	22uF*2	45.3K	10K	13K	3.3nF	N/A

BOM List for EN Pin Application

V_{IN} (V)	R4	R5	V_{EN} (V)
4.5	100k	NC	4.40
5	100k	NC	4.60
9	100k	110k	4.71
12	100k	62k	4.59
15	100k	43k	4.51
18	100k	36k	4.75

Functional Pin Description

Pin No.	Pin Name	Pin Function
1	BOOT	Bootstrap Supply for the Floating Upper Gate Driver. Connect the bootstrap capacitor C_{BOOT} between BOOT pin and the LX pin to form a bootstrap circuit. The bootstrap capacitor provides the charge to turn on the upper MOSFET. Typical value for C_{BOOT} is 10nF or greater. Ensure that C_{BOOT} is placed near the IC.
2	VIN	Power Supply Input. Input voltage that supplies current to the output voltage and powers the internal control circuit. Bypass the input voltage with a minimum 10uFx2 X5R or X7R ceramic capacitor.
3	LX	Internal Switches Output. Connect this pin to the output inductor.
4	GND	Ground. Ground of the buck converter.
5	FB	Switcher Feedback Voltage. This pin is the inverting input of the error amplifier. FB senses the switcher output through an external resistor divider network.
6	COMP	Compensation. This pin is output of the error amplifier. The current comparator threshold increases with this control voltage. Connect a RC network to ground for controlling loop compensation.
7	EN	Buck Converter Enable (Active High). A logic low forces the converter into shutdown mode reducing the supply current to less than 1uA. Attach this pin to VIN with a 100kΩ pull up resistor for automatic startup.
8	SS	Soft-Start Control Pin. Connect a softstart capacitor C_{SS} to this pin. Leave open for no soft-start application. The softstart capacitor is discharged to ground when EN pin is low.

Functional Block Diagram

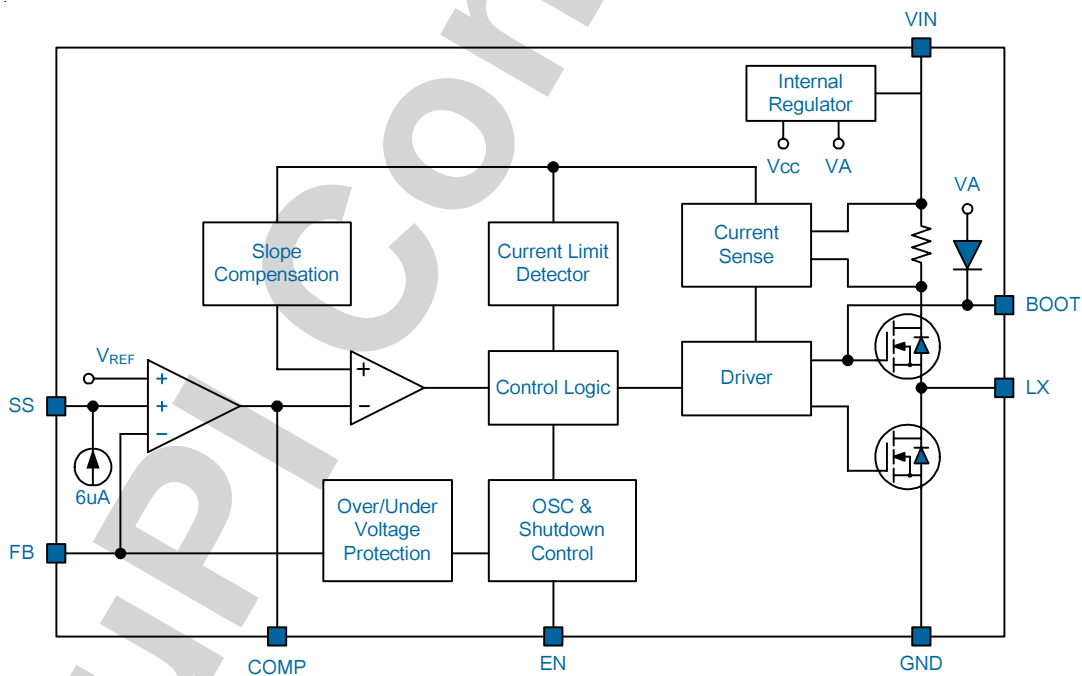

Functional Description

The integrated high efficiency synchronous-rectified buck converter with internal power switches. With internal low $R_{DS(ON)}$ switches, it is capable of delivering 2A output current over a wide input voltage range from 4.5V to 18V. The output voltage is adjustable from 0.925V to 16V by a voltage divider. Other features include Programmable soft-start, chip enable, overvoltage, under-voltage, over-temperature and over-current protections.

Input Supply Voltage, VIN

VIN supplies current to internal control circuits and output voltages. The supply voltage range is from 4.5V to 18V. A power on reset (POR) continuously monitors the input supply voltage. The POR level is typically 4.2V at VIN rising. The buck converter draws pulsed current with sharp edges each time the upper switch turns on, resulting in voltage ripples and spikes at supply input. A minimum 10uF x 2 ceramic capacitor with shortest PCB trace is highly recommended for bypassing the supply input.

Chip Enable/Disable and Soft Start

Pulling EN pin lower than 0.6V shuts down the buck converter and reduces its quiescent current lower than 1uA. In the shutdown mode, both upper and lower switches are turned off. Pulling EN pin higher than 2.1V enables the buck converter and initiates the soft start cycle.

The uP1715 features programmable soft start function to limit the inrush current from supply input by a soft start capacitor C_{SS} connected to SS pin as shown in Figure 1. The C_{SS} is charged to VIN by a 6uA current source when EN pin is taken high. The V_{SSE} voltage is clamped to V_{SS} with a threshold voltage of NMOSFET.

The error amplifier is a tri-input device. V_{SSE} or V_{REF} whichever is smaller dominates the non-inverting inputs of the error amplifier. The V_{SSE} voltage starts ramping up when V_{SS} is higher than about 0.7V. The V_{FB} voltage will follow the V_{SSE} and ramp up linearly. When V_{SSE} is higher than V_{REF} , the uP1715 asserts soft start end and the V_{FB} voltage is regulated to V_{REF} . Soft start end also initiates the output under voltage protection.

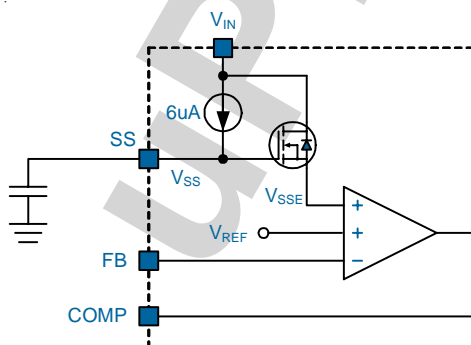

Figure 1. uP1715 Soft Start

Main Control Loop

The uP1715 adopts slope-compensated, current mode PWM control. During normal operation, the uP1715 operates at PWM mode to regulate output voltage by transferring the power to the output voltage cycle by cycle at a constant frequency. The uP1715 turns on the upper switch at each rising edge of the internal oscillator allowing the inductor current to ramp up linearly. The switch remains on until either the current limit is tripped or the PWM comparator turns off the switch for regulating output voltage.

The lower switch turns on with optimal dead time and picks up the inductor current after the upper switch turns off allowing the inductor current to ramp down linearly. The switch remains on until the next rising edge of oscillator turns on the upper switch. The uP1715 regulates the output voltage by controlling the ramp up/down duty cycle of inductor current. The high frequency switching ripple is easily smoothed by the output filter.

The upper switch current is sensed, slope compensated and compared with the error amplifier output COMP to determine the adequate duty cycle. The feedback voltage V_{FB} is sensed through a resistive voltage divider and regulated to internal 0.925V reference voltage. The error amplifier amplifies and compensates voltage variation to get appropriate COMP pin voltage.

When the load current increases, it causes a slight decrease in the feedback voltage relative to the 0.925V reference, which in turn, causes the error amplifier output voltage to increase until the average inductor current matches the new load current.

Output Voltage Setting and Feedback Network

For the adjustable output version, the output voltage can be set from V_{REF} to VIN by a voltage divider as:

$$V_{OUT} = 0.925V \times \frac{R1+R2}{R2}$$

The internal V_{REF} is 0.925V with 1.5% accuracy. In real applications, a 22pF feed-forward ceramic capacitor is recommended in parallel with R1 for better transient response.

Over Temperature Protection

The OTP is triggered and shuts down the uP1715 if the junction temperature is higher than 160°C. The OTP is a non-latch type protection. The uP1715 automatically initiates another soft start cycle if the junction temperature drops below 130°C.

Absolute Maximum Rating

(Note 1)

Supply Input Voltage, V_{IN}	-----	-0.3V to +20V
LX Pin Voltage		
DC	-----	-0.3V to $+(V_{IN} + 0.3V)$
<50ns	-----	-3.5V to +25V
BOOT Pin Voltage	-----	-0.3V to (LX + 6.0V)
Other Pins	-----	-0.3V to 6V
Storage Temperature Range	-----	-65°C to +150°C
Junction Temperature	-----	150°C
Lead Temperature (Soldering, 10 sec)	-----	260°C
ESD Rating (Note 2)		
HBM (Human Body Mode)	-----	2kV
MM (Machine Mode)	-----	200V

Thermal Information

Package Thermal Resistance (Note 3)

SOP-8L θ_{JA}	-----	160°C/W
SOP-8L θ_{JC}	-----	39°C/W
PMSOP-8L θ_{JA}	-----	86°C/W
PMSOP-8L θ_{JC}	-----	30°C/W
Power Dissipation, P_D @ $T_A = 25^\circ\text{C}$		
SOP-8L	-----	0.62W
PMSOP-8L	-----	1.16W

Recommended Operation Conditions

(Note 4)

Operating Junction Temperature Range	-----	-40°C to +125°C
Operating Ambient Temperature Range	-----	-40°C to +85°C

Electrical Characteristics

 ($V_{IN} = 12V$, $T_A = 25^\circ\text{C}$, unless otherwise specified)

Parameter	Symbol	Test Conditions	Min	Typ	Max	Units
Supply Current						
Supply Current		$V_{EN} = 3.0V$, $V_{FB} = 1.0V$	--	0.8	1.2	mA
Shutdown Supply Current		$V_{EN} = 0V$	--	0.3	3	µA
Input Under Voltage Lockout Threshold		V_{IN} rising	4	4.2	4.4	V
Input Under Voltage Lockout Threshold Hysteresis			--	350	--	mV
Reference						
Feedback Voltage	V_{FB}	$4.75V < V_{IN} < 18V$	0.911	0.925	0.939	V
Error Amplifier Transconductance	GEA	$\Delta IC = +/-10\mu A$	600	820	950	µA/V
COMP to Current Sense Transconductance	GCS		--	3.6	--	A/V

Electrical Characteristics

Parameter	Symbol	Test Conditions	Min	Typ	Max	Units
Power Switches						
Hide-Side Switch On Resistance	$R_{DS(ON)}$		90	130	170	m Ω
Low-Side Switch On Resistance	$R_{DS(ON)}$		90	130	170	m Ω
High-Side Switch Leakage Current		$V_{EN} = 0V, V_{SW} = 0V$	--	0	10	μA
Upper Switch Current Limit		Minimum Duty Cycle	3.4	4	5.5	A
Lower Switch Current Limit		From Drain to Source	--	0.8	--	A
Oscillator						
Oscillation Frequency	FOSC1		300	340	380	kHz
Short Circuit Oscillation Frequency	FOSC2	$V_{FB} = 0V$	90	110	130	kHz
Maximum Duty Cycle	DMAX	$V_{FB} = 1.0V$	85	90	95	%
Minimum On Time	TON		--	120	--	ns
Logic Input						
EN Logic High		V_{EN} Rising	2.1	--	--	V
EN Logic Low		V_{EN} Falling	--	--	0.6	V
Soft Start						
Soft-Start Current		$V_{SS} = 0V$	5.5	6.0	6.5	μA
Protection						
FB Over Voltage Protection			1.0	1.1	1.3	V
Over-Temperature Protection			--	160	--	$^{\circ}C$
Over-Temperature Hysteresis			--	30	--	$^{\circ}C$

Note 1. Stresses listed as the above *Absolute Maximum Ratings* may cause permanent damage to the device. These are for stress ratings. Functional operation of the device at these or any other conditions beyond those indicated in the operational sections of the specifications is not implied. Exposure to absolute maximum rating conditions for extended periods may remain possibility to affect device reliability.

Note 2. Devices are ESD sensitive. Handling precaution recommended.

Note 3. θ_{JA} is measured in the natural convection at $T_A = 25^{\circ}C$ on a low effective thermal conductivity test board of JEDEC 51-3 thermal measurement standard.

Note 4. The device is not guaranteed to function outside its operating conditions.

Typical Operation Characteristics

Power On Waveforms

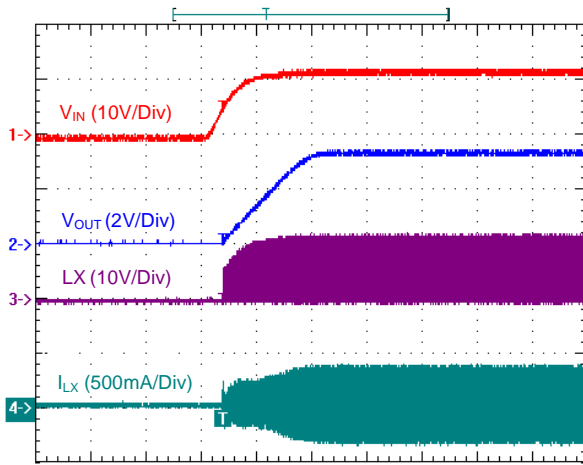

10ms/Div
 $V_{IN} = 12V, V_{OUT} = 3.3V, I_{OUT} = 0A$

Power On Waveforms

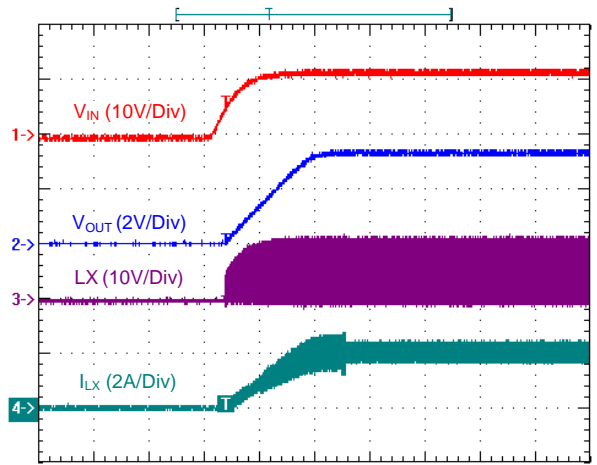

10ms/Div
 $V_{IN} = 12V, V_{OUT} = 3.3V, I_{OUT} = 2A$

Turn On Waveforms

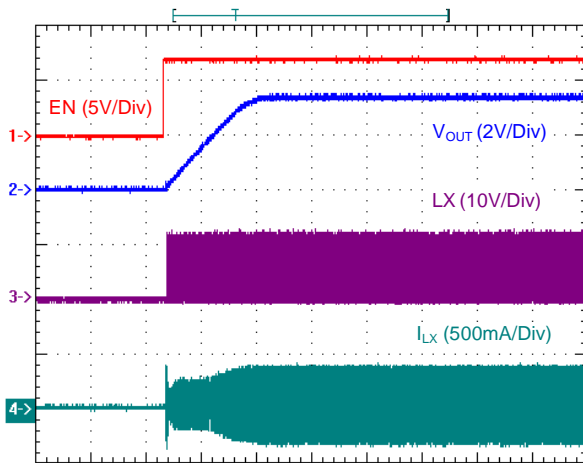

10ms/Div
 $V_{IN} = 12V, V_{OUT} = 3.3V, I_{OUT} = 0A$

Turn On Waveforms

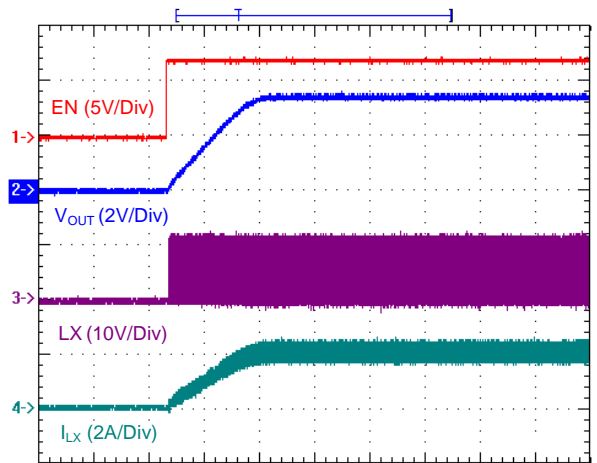

10ms/Div
 $V_{IN} = 12V, V_{OUT} = 3.3V, I_{OUT} = 2A$

Turn Off Waveforms

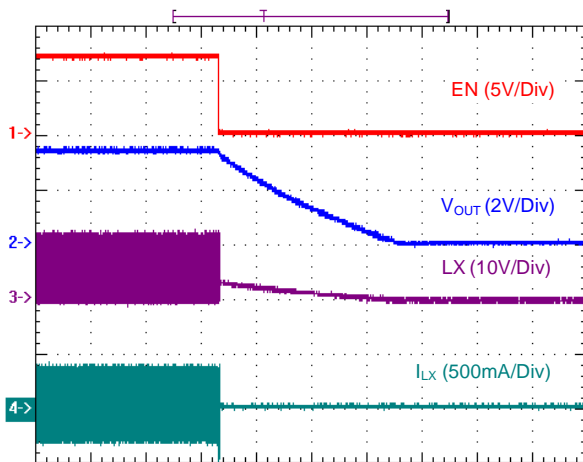

200ms/Div
 $V_{IN} = 12V, V_{OUT} = 3.3V, I_{OUT} = 0A$

Turn Off Waveforms

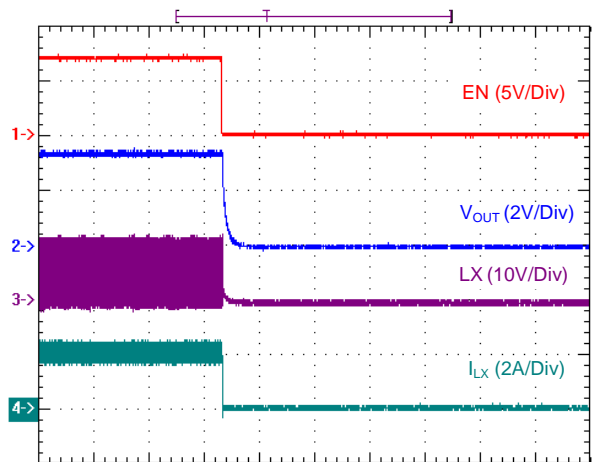

20us/Div
 $V_{IN} = 12V, V_{OUT} = 3.3V, I_{OUT} = 2A$

Typical Operation Characteristics

Steady State Waveforms

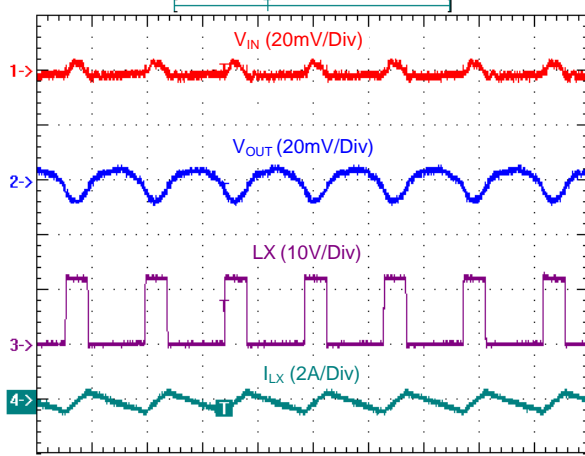

2us/Div
 $V_{IN} = 12V, V_{OUT} = 3.3V, I_{OUT} = 0A$

Steady State Waveforms

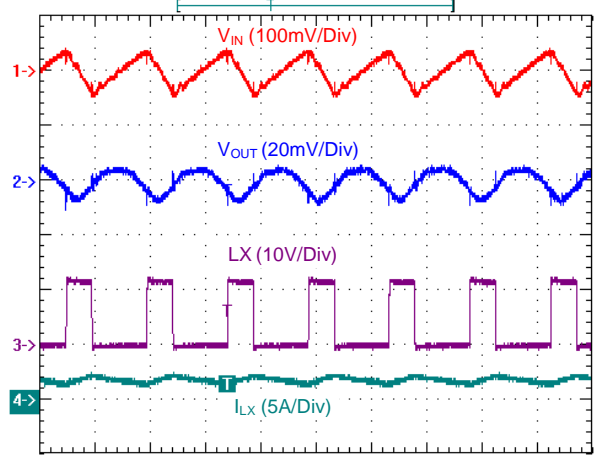

2us/Div
 $V_{IN} = 12V, V_{OUT} = 3.3V, I_{OUT} = 2A$

Load Transient Test Waveforms

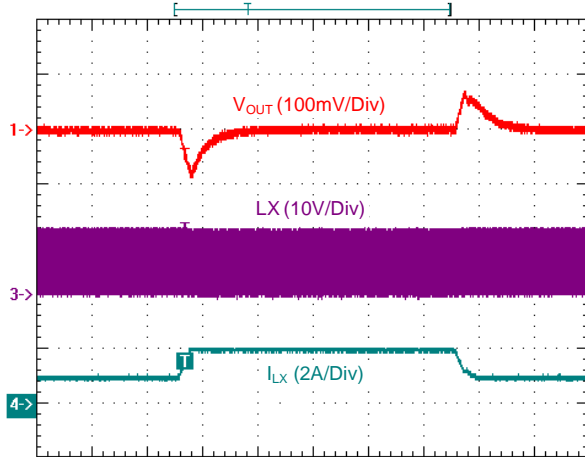

100us/Div
 $V_{IN} = 12V, V_{OUT} = 3.3V, I_{OUT} = 1A \sim 2A$

Efficiency vs. Output Current

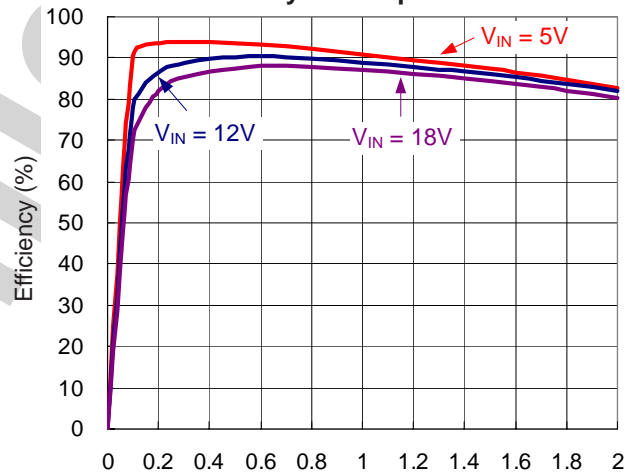

$V_{IN} = 5V \sim 18V, V_{OUT} = 3.3V, I_{OUT} = 0A \sim 2A$

Output Voltage vs. Output Current

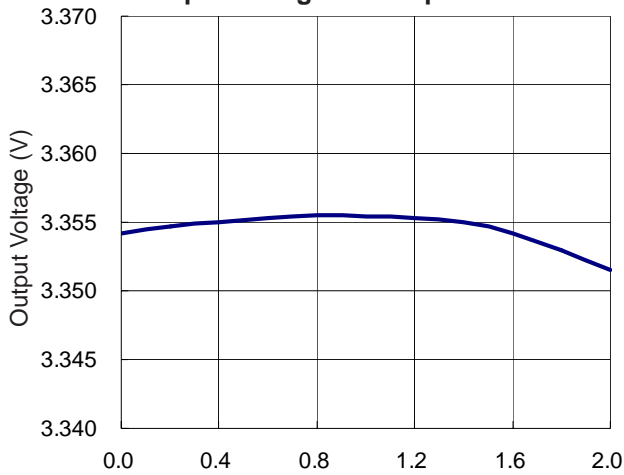

$V_{IN} = 12V, V_{OUT} = 3.3V, I_{OUT} = 0A \sim 2A$

Frequency vs. Output Current

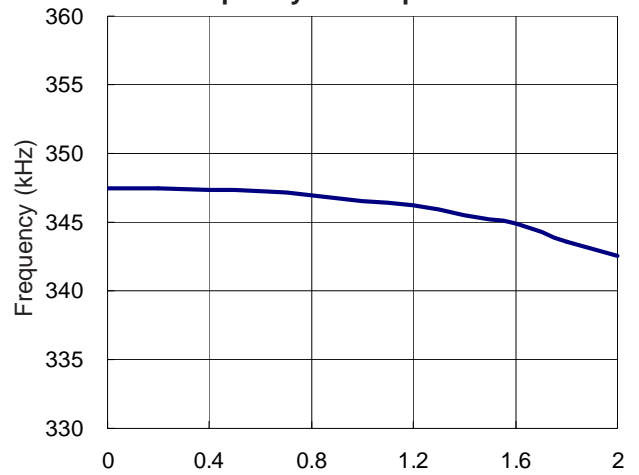

$V_{IN} = 12V, V_{OUT} = 3.3V, I_{OUT} = 0A \sim 2A$

Application Information

Output Inductor Selection

Output inductor selection is usually based the considerations of inductance, rated current value, size requirements and DC resistance (DCR).

The inductance is chosen based on the desired ripple current. Large value inductors result in lower ripple currents and small value inductors result in higher ripple currents. Higher V_{IN} or V_{OUT} also increases the ripple current as shown in the equation below. A reasonable starting point for setting ripple current is $\Delta I_L = 900\text{mA}$ (30% of 3000mA). For most applications, the value of the inductor will fall in the range of 1uH to 10uH.

$$\Delta I_L = \frac{1}{f_{OSC} \times L_{OUT}} \times V_{OUT} \left(1 - \frac{V_{OUT}}{V_{IN}}\right)$$

Maximum current ratings of the inductor are generally specified in two methods: permissible DC current and saturation current. Permissible DC current is the allowable DC current that causes 40°C temperature raise. The saturation current is the allowable current that causes 10% inductance loss. Make sure that the inductor will not saturate over the operation conditions including temperature range, input voltage range, and maximum output current. If possible, choose an inductor with rated current higher than 3.4A so that it will not saturate even under current limit condition.

The size requirements refer to the area and height requirement for a particular design. For better efficiency, choose a low DC resistance inductor. DCR is usually inversely proportional to size.

Different core materials and shapes will change the size, current and price/current relationship of an inductor. Toroid or shielded pot cores in ferrite or permalloy materials are small and don't radiate much energy, but generally cost more than powdered iron core inductors with similar electrical characteristics. The choice of which style inductor to use often depends on the price vs. size requirements and any radiated field/EMI requirements.

Input Capacitor Selection

The buck converter draws pulsed current with sharp edges from the input capacitor resulting in ripple and noise at the input supply voltage. A minimum 10uFx2 X5R or X7R ceramic capacitor is highly recommended to filter the pulsed current. The input capacitor should be placed as near the device as possible to avoid the stray inductance along the connection trace. Y5V dielectrics, aside from losing most of their capacitance over temperature, they also become resistive at high frequencies. This reduces their ability to filter out high frequency noise.

The capacitor with low ESR (equivalent series resistance) provides the small drop voltage to stabilize the input voltage during the transient loading. For input capacitor selection, the ceramic capacitor larger than 10uFx2 is recommend. The capacitor must conform to the RMS current requirement. The maximum RMS ripple current is calculated as:

$$I_{IN(RMS)} = I_{OUT(MAX)} \times \frac{\sqrt{V_{OUT} \times (V_{IN} - V_{OUT})}}{V_{IN}}$$

This formula has a maximum at $V_{IN} = 2 \times V_{OUT}$, where $I_{IN(RMS)} = I_{OUT(MAX)} / 2$. This simple worst-case condition is commonly used for design because even significant deviations do not offer much relief. Note that the capacitor manufacturer's ripple current ratings are often based on 2000 hours of life. This makes it advisable to further derate the capacitor, or choose a capacitor rated at a higher temperature than required. Always consult the manufacturer if there is any question.

Output Capacitor Selection

The integrated buck converter is specifically design to operate with minimum 22uFx2 X5R or X7R ceramic capacitor. The value can be increased to improve load/line transient performance. Y5V dielectrics, aside from losing most of their capacitance over temperature, they also become resistive at high frequencies. This reduces their ability to filter out high frequency noise.

The ESR of the output capacitor determines the output ripple voltage and the initial voltage drop following a high slew rate load transient edge. The output ripple voltage can be calculated as:

$$\Delta V_{OUT} = \Delta I_C \times \left(ESR + \frac{1}{8 \times f_{OSC} \times C_{OUT}} \right)$$

where f_{OSC} = operating frequency, C_{OUT} = output capacitance and $\Delta I_C = \Delta I_L$ = ripple current in the inductor.

The ceramic capacitor with low ESR value provides the low output ripple and low size profile. Connect a 1uF/10uF ceramic capacitor at output terminal for good performance and place the input and output capacitors as close as possible to the device.

Using Ceramic Capacitors

Higher value, lower cost ceramic capacitors are now available in smaller case sizes. Their high ripple current, high voltage rating and low ESR make them ideal for switching regulator applications. Because the control loop does not depend on the output capacitor's ESR for stable operation, ceramic capacitors can be used to achieve very low output ripple and small circuit size.

SOP-8L

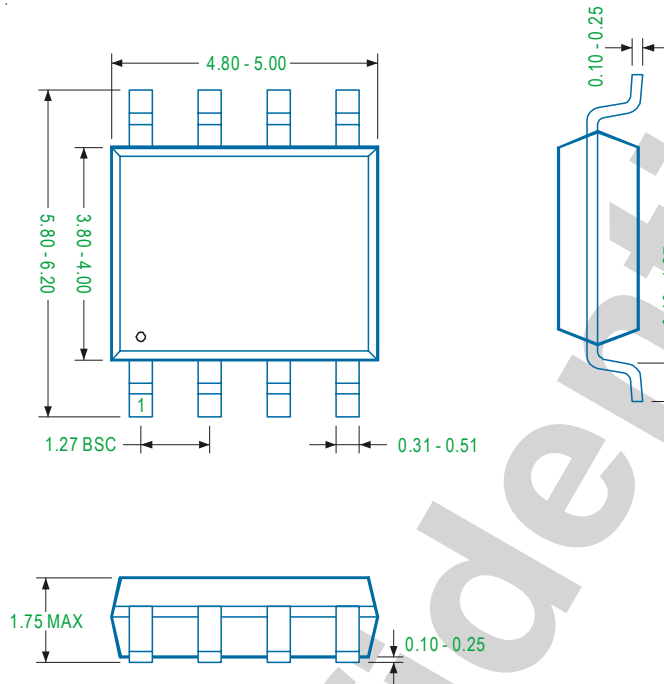

Note

1. Package Outline Unit Description:

BSC: Basic. Represents theoretical exact dimension or dimension target

MIN: Minimum dimension specified.

MAX: Maximum dimension specified.

REF: Reference. Represents dimension for reference use only. This value is not a device specification.

TYP: Typical. Provided as a general value. This value is not a device specification.

2. Dimensions in Millimeters.

3. Drawing not to scale.

4. These dimensions do not include mold flash or protrusions. Mold flash or protrusions shall not exceed 0.15mm.

PMSOP-8L

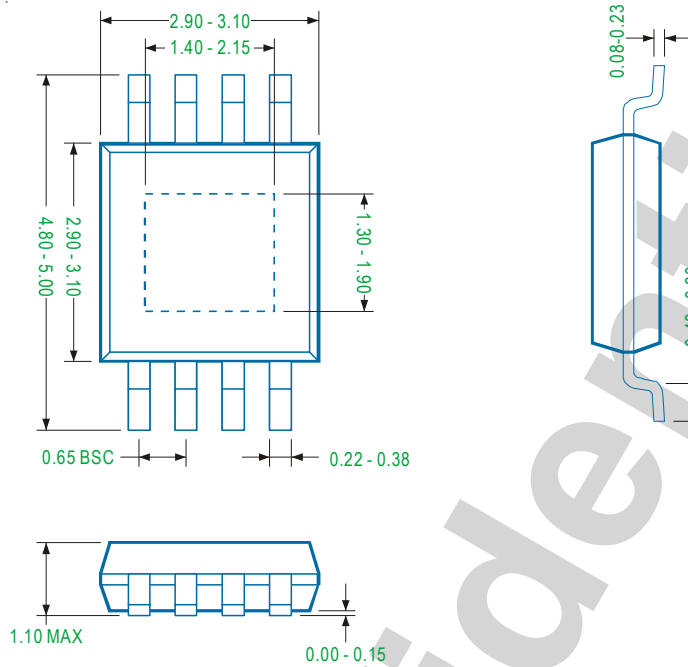

Note

1. Package Outline Unit Description:

BSC: Basic. Represents theoretical exact dimension or dimension target

MIN: Minimum dimension specified.

MAX: Maximum dimension specified.

REF: Reference. Represents dimension for reference use only. This value is not a device specification.

TYP: Typical. Provided as a general value. This value is not a device specification.

2. Dimensions in Millimeters.

3. Drawing not to scale.

4. These dimensions do not include mold flash or protrusions. Mold flash or protrusions shall not exceed 0.15mm.

Important Notice

UPI and its subsidiaries reserve the right to make corrections, modifications, enhancements, improvements, and other changes to its products and services at any time and to discontinue any product or service without notice. Customers should obtain the latest relevant information before placing orders and should verify that such information is current and complete.

UPI products are sold subject to the terms and conditions of sale supplied at the time of order acknowledgment. However, no responsibility is assumed by UPI or its subsidiaries for its use; nor for any infringements of patents or other rights of third parties which may result from its use. No license is granted by implication or otherwise under any patent or patent rights of UPI or its subsidiaries.

COPYRIGHT (c) 2010, UPI SEMICONDUCTOR CORP.

UPI Semiconductor Corp.

Headquarter

9F., No. 5, Taiyuan 1st St. Zhubei City,
Hsinchu Taiwan, R.O.C.

TEL : 886.3.560.1666 FAX : 886.3.560.1888

Sales Branch Office

12F-5, No. 408, Ruiguang Rd. Neihu District,
Taipei Taiwan, R.O.C.

TEL : 886.2.8751.2062 FAX : 886.2.8751.5064