

Low Standby-Power Off-line PWM converters

General Description

The PN8106 consists of an integrated Pulse Width Modulator (PWM) controller and power MOSFET, specifically designed for a high performance off-line converter with minimal external components. PN8106 offers complete protection coverage with automatic self-recovery feature including Cycle-by-Cycle current limiting (OCP), over voltage (OVP) and overload protection (OLP), over temperature protection (OTP) and soft-start. Burst mode operation and device very low consumption helps to meet the standby energy saving regulations. Excellent EMI performance is achieved with frequency modulation. The device consists of the high voltage start-up circuit. The device provides an advanced platform well suited for low standby-power and cost-effective flyback converters.

Features

- Internal 730 V avalanche-rugged power MOSFET
- Operating Frequency(60kHz)
- Frequency modulation for low EMI
- Burst-mode Operation
- No-load consumption power < 40 mW @220VAC
- Built-in Soft Start
- Internal HV Start-up Circuit
- Open frame output power >18W @230VAC
- Excellent Protection Coverage:
 - ◇ Over Temperature Protection (OTP)
 - ◇ Adjustable and accurate Over Voltage Protection (OVP)
 - ◇ Adjustable Pulse-by-Pulse Over Current Protection (OCP)
 - ◇ Over Load Protection (OLP)
 - ◇ Auto- recovery protection Mode

Applications

- Switch AC/DC Adaptor and Battery Charger
- Auxiliary Power for White Goods, PC,Audio
- LCD /PDP TV Power
- LED Drivers

Pin Assignments

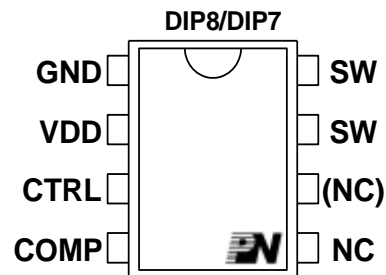

Typical Application Schematic

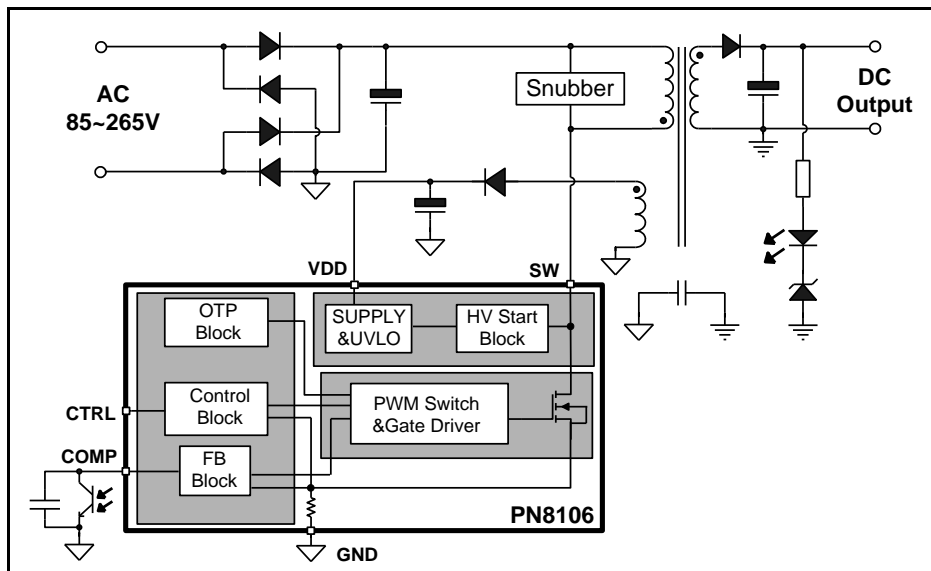

Pin Definitions

Table 1. Pin Definitions

Pin Number	Pin Name	Pin Function Description
1	GND	Ground.
2	VDD	Positive Supply voltage Input..
3	CTRL	Control pin of adjustable Pulse-by-Pulse Current Limiting and output voltage monitoring.
4	COMP	Voltage feedback. By connecting a opto-coupler to close the control loop and achieve the regulation.
5	NC	No connection
6		
7	SW	HV MOSFET Drain pin. The Drain pin is connected to the primary lead of the transformer.
8		

Note: NC Pin can not be connected

Typical power

Table 2. Typical power

Part number		Adapter ⁽¹⁾	Open frame ⁽²⁾
PN8106	230 V _{AC}	16W	18 / 23W
	85-265 V _{AC}	10W	12 / 17W

Note:

1. Typical continuous power in a non-ventilated enclosed adapter measured at 55 °C ambient temperature.
2. Maximum practical continuous power in an open-frame design at 55 °C and 25 °C ambient.

Absolute Maximum Ratings

Supply voltage Pin VDD.....	-0.3~20V
High-Voltage Pin, SW.....	730V
Pin CTRL, COMP.....	-0.3~5.5V
Operating Junction Temperature.....	-40~140°C
Storage Temperature Range.....	-55~150°C
Lead Temperature.....	250°C
Package Thermal Resistance (DIP-8).....	100°C/W
Power Dissipation (DIP-8, at Ambient Temperature = 85°C).....	1W
ESD voltage Protection (HBM).....	4.0kV
Pulse drain current.....	3.0A

Electrical Characteristics

($T_j = 25\text{ }^\circ\text{C}$, $V_{DD} = 14\text{ V}$; unless otherwise specified)

Table 3. Power section

SYMBOL	PARAMETER	CONDITIONS	MIN	TYP	MAX	UNIT
V _{BVDSS}	Break-down voltage	I _{SW} = 250uA, V _{COMP} = GND, T _J = 25 °C	730	750		V
I _{OFF}	Off-state drain current	V _{SW} = 600 V, V _{COMP} = GND			100	uA
R _{DS(on)}	Drain-source on state resistance	I _{SW} = 0.4A, V _{COMP} = 3V, V _{LUV} = GND, T _J = 25 °C		6	7	Ω
		I _{SW} = 0.4A, V _{COMP} = 3V, T _J = 125 °C		12	14	Ω
C _{OSS}	Effective output capacitance	V _{SW} = 0~640 V		22		pF

Table 4. Supply section

SYMBOL	PARAMETER	CONDITIONS	MIN	TYP	MAX	UNIT
VOLTAGE						
V _{SW_START}	Drain-source start voltage		60	80	100	V
I _{DD_CH}	Start up charging current	V _{SW} = 100 V, V _{COMP} = GND, V _{DD} = 4 V		-3		mA
		V _{SW} = 100 V, V _{COMP} = GND, V _{DD} = 4 V after fault.		-0.6		mA
V _{DD}	Operating voltage range	After turn-on	8.5		18	V
V _{DDclamp}	V _{DD} clamp voltage	I _{DD} = 20 mA	20			V
V _{DDon}	V _{DD} start up threshold		12	13	14	V
V _{DDoff}	V _{DD} under voltage shutdown threshold	V _{SW} = 120 V, V _{COMP} = GND	7	8	9	V
V _{DD(RESTART)}	V _{DD} restart voltage threshold	V _{SW} = 120 V, V _{COMP} = GND	4	4.5	5	V
SUPPLY CURRENT SECTION						
I _{DD0}	Operating supply current, not switching	V _{COMP} = GND, F _{sw} = 0 kHz, V _{LUV} = GND, V _{DD} = 10 V			0.9	mA
I _{DD1}	Operating supply current, switching	V _{SW} = 120 V, F _{sw} = 62 kHz			1.7	mA
I _{DD_FAULT}	Operating supply current, with protection tripping			280	350	uA
I _{DD_OFF}	Operating supply current with V _{DD} < V _{DD_OFF}	V _{DD} = 7 V		240	300	uA

Table 5. Controller section ($T_J = 25\text{ }^\circ\text{C}$, $V_{DD} = 14\text{ V}$; unless otherwise specified)

SYMBOL	PARAMETER	CONDITIONS	MIN	TYP	MAX	UNIT
COMP pin						
V _{COMP_olp}	Over load shut down threshold		4.5	4.8	5.2	V
V _{COMP_lin}	Linear dynamics upper limit		3.1	3.4	3.6	V
V _{COMP_bm}	Burst mode threshold	Voltage falling		0.45		V
V _{COMP_bm_hys}	Burst mode hysteresis	Voltage rising		50		mV
I _{COMP}	Feedback sourced current	V _{COMP} = 0.3 V	-150	-200	-280	uA
		3.3 V < V _{COMP} < 4.8 V		-3		uA
CTRL pin						
V _{CTRL_l}	Low level clamp voltage	I _{CTRL} = -100 uA		0.5		V
CURRENT LIMIT						
I _{Dlim}	Max drain current limitation	V _{COMP} = 4 V, I _{CTRL} = -10 μA T _J = 25 °C	0.72	0.8	0.88	A
t _{SS}	Soft-start time			8.5		ms
T _{ON_MIN}	Minimum turn ON time			450		ns
t _d	Propagation delay			150		ns
t _{LEB}	Leading edge blanking			300		ns
I _{D_BM}	Peak drain current during burst mode	V _{COMP} = 0.6 V	160		180	mA
OSCILLATOR SECTION						
F _{OSC}	Switching Frequency	V _{DD} = operating voltage range, V _{COMP} = 1 V	54	60	66	kHz
FD	Frequency Variation			±5		kHz
FM	Modulation frequency			250		Hz
D _{MAX}	Maximum duty cycle		70		80	%
OVER VOLTAGE PROTECTION (OVP)						
V _{OVP}	Over voltage protection threshold		2.7	3	3.3	V
T _{STROBE}	Over voltage protection strobe time			2.2		us
THERMAL SECTION						
T _{SD}	Thermal shutdown temperature		140	160		°C
THYST	Thermal shutdown hysteresis			30		°C

Typical circuit

Figure 1. Flyback application (basic)

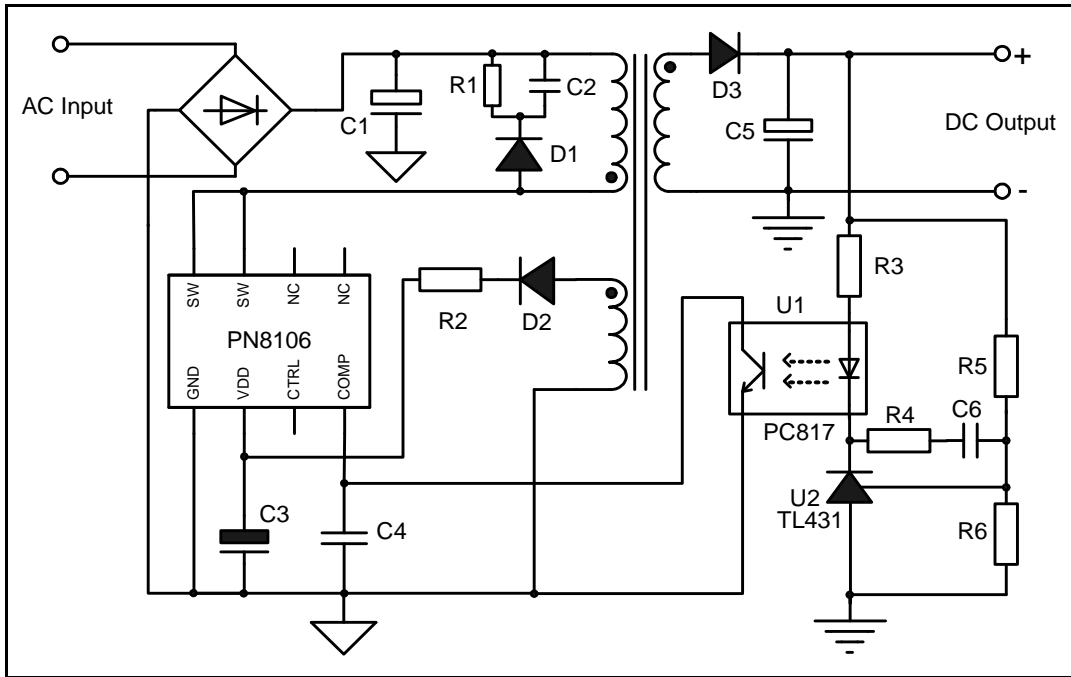
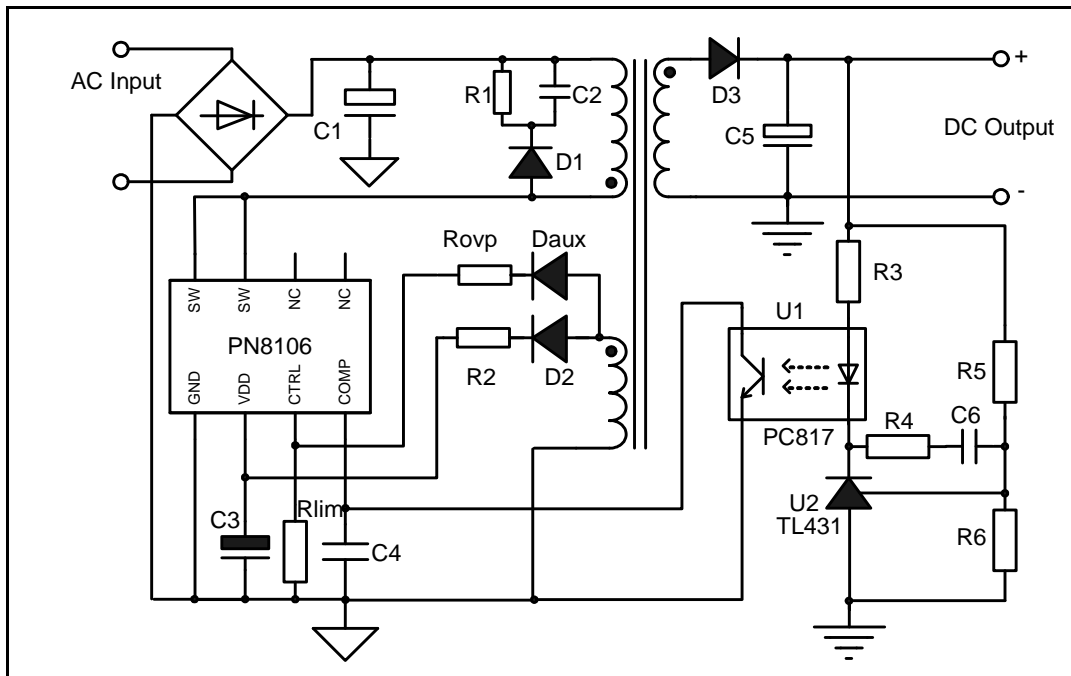

Figure 2. Flyback application



Operation Description

1. Startup

At start up, the internal high-voltage current source supplies the internal bias and charges the external VDD capacitor. When VDD reaches 13V, the device starts switching and the internal high-voltage current source stops charging the capacitor. The device is in normal operation provided VDD does not drop below 8V. After start up, the bias is supplied from the auxiliary transformer winding.

When high voltage current source is turned on, the charge current of the VDD capacitance is 3mA. If a fault happen, the circuit enter auto-recovery mode and IDD charge current is turned to 0.6mA.

2. Soft-start up

In the process of start up, the current of drain increases to maximum limitation step by step. As a result, it can reduce the stress of secondary diode greatly and is propity to prevent the transformer turning into the saturation states.

Typically, the duration of soft-start is 8.5ms.

3. Gate driver

The internal power MOSFET in PN8106 is driven by a dedicated gate driver for power switch control. Too weak the gate driver strength results in higher conduction and switch loss of MOSFET while too strong gate drive results in worse EMI.

A good tradeoff is achieved through the built-in totem pole gate design with proper output strength and dead time. The good EMI system design and low idle loss is easier to achieve with this dedicated control scheme.

4. Oscillator

The switching frequency of PN8106 is internally fixed at 60 kHz. No external frequency setting components are required for PCB design.

The frequency modulation is implemented in PN8106. So that, it minimizes the conduction band EMI and therefore eases the system design because the tone energy could be spread out.

5. Feed-back

The PN8106 is a current mode controlled device. The feedback voltage is compared with an internally generated saw-tooth waveform. This controls the duty cycle directly.

6. Over load protection (OLP)

Overload is defined as the load current exceeding a pre-set level due to an accident event as a fault. In this case, the protection circuit should be activated to protect the SMPS. If VCOMP exceeds 3.4V, the feedback input diode is blocked and the 3uA current source starts to charge CCOMP slowly up. In this case, VCOMP increases until it reaches 4.8V, when the switching operation is terminated. The delay time from the overload detection to the device shutdown required to charge CCOMP from 3.4V to 4.8V with a 3uA current source.

7. Burst-mode operation

PN8106 enters burst-mode operation in order to minimize the power dissipation in standby mode. As the load decreases, the feedback voltage decreases. When the voltage on COMP pin falls below 0.45V typ, VCOMP_{bm}, the device enters

burst mode and power MOSFET stops switching. It can be switched on again once the voltage on COMP pin exceeds 50mV over V_{COMPbm} . The switching frequency control also eliminates the audio noise at any loading condition.

8. Adjustable current limit of over current protection (OCP)

Cycle-by-Cycle current limiting is offered in PN8106 current mode converter. The switch current is detected by a sense resistor into the sense pin. The current limiting comparator is disabled and cannot turn off the power MOSFET during the blanking time. PN8106 have a maximum current limit. And also, the system designers could regulate this parameter through changing the R_{lim} value. see [Figure 3](#).

Figure 3. Current limit vs R_{lim} .

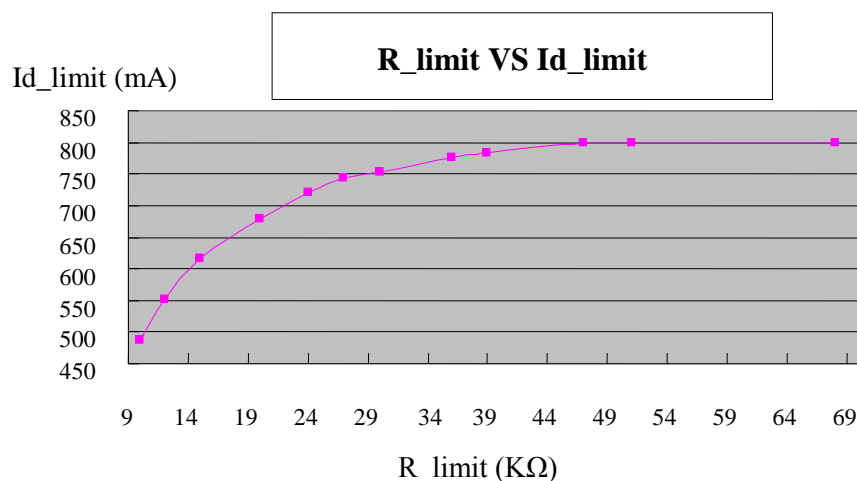

9. Over voltage protection(OVP)

OVP function is achieved by CTRL pin which connects with the auxiliary transformer through the divided resistance in order to control and monitor the output voltage. While CTRL pin voltage is detected during the MOSFET off-time, if the detected voltage exceeds 3V for sequential four cycles, then OVP out signal turn into '1', over voltage protection enable. As a result, the device shut down and system enters auto- recovery mode operation.

10. About CTRL pin

Table6. CTRL pin configurations

Function	Optional	R_{lim}	Rovp	Daux
Adjustable current limit	Yes	see Figure 3	No	No
OVP	Yes	=68KΩ	Yes	Yes
Adjustable current limit+ OVP	No	/	/	/

11. Over temperature protection (OTP)

The power MOSFET and control chip are integrated, making it easier for control chip to detect the temperature of MOSFET. If the temperature exceeds about 160°C, OTP fault is activated.

Package Dimensions (DIP8 / DIP7)

Table 7. DIP8 mechanical data

Size symbol	Min(mm)	Max(mm)	Size symbol	Min(mm)	Max(mm)
A	9.30	9.50	C2	0.50	
A1	1.524		C3	3.3	
A2	0.39	0.53	C4	1.57TYP	
A3	2.54		D	8.2	8.8
A4	0.66TYP		D1	0.2	0.35
A5	0.99TYP		D2	7.62	7.87
B	6.3	6.5	∅1	8 TYP	
C	7.2		∅2	8 TYP	
C1	3.3	3.5	∅3	5 TYP	

Figure4. Package dimensions

